

KEF instOnt dvd theatre



surround yourself with sound not speakers

Contents	KEF instant theatre™	2
	KIT beautifully simple	4
	KIT experience	6
	KIT works	8
	KIT accessories	12
	KIT specifications	13

KEF instant theatre



You only have to go to the cinema to realise what you're missing when you watch movies on TV without a decent home theatre system. Trouble is, conventional 5.1 set-ups are such a hassle to install. For a start, you've got to find room for six speakers – and they all have to be placed in exactly the right position, irrespective of whether or not they look good there. Cables have to be run along walls or under the floor to reach the rear effects speakers. And your room ends up looking more like a hi-fi store than a place to relax.

Not any more. KEF instant theatre is a complete DVD-based system that gives you everything you need to experience true digital surround sound from just two compact front speakers and a hide-away subwoofer - and you enjoy the same detailed 3D sound image wherever you sit. The sense of 'being there' is spellbinding. But there's nothing magic about it - just clever technology you won't find elsewhere. We've crammed everything we've learned in over 40 innovative years of award-winning high-end loudspeaker design into KEF instant theatre. The result is sound for the way we live today.



KEF awards



surround yourself with sound
not speakers

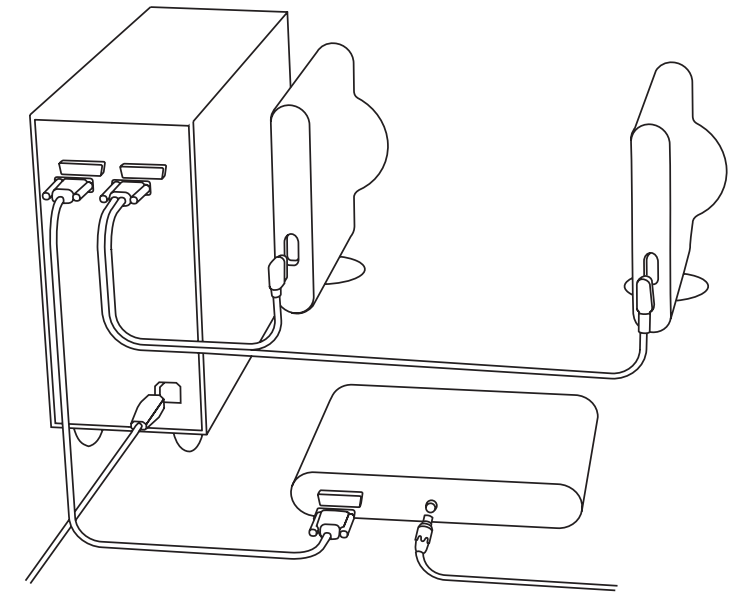

KIT beautifully simple

KEF instant theatre was designed from the start to be a complete system with everything you need to enjoy high quality surround sound in minutes. It really couldn't be simpler to set up. All you have to do is plug in the subwoofer to the mains and connect only four other cables (using plugs shaped to make incorrect fitting impossible). Then just switch on, load your disc, sit back and relax.



sound for the way
we live today



KIT experience

Simplicity and integrity are what KEF instant theatre is all about: an awesomely competent system that's as easy on the eye as it is easy to set up. Playing any of today's digital formats, it allows you to experience the sense of total involvement you get with Dolby® Digital surround sound without cluttering up your room with hardware. Vocals come across as clear, true and precisely located. The ambient soundscape is highly detailed and compellingly three-dimensional. And bass effects are reproduced with the drama the director intended. So what's on screen comes alive – for everyone in the room, wherever they happen to be sitting.



just minutes to set up
endless hours of pleasure

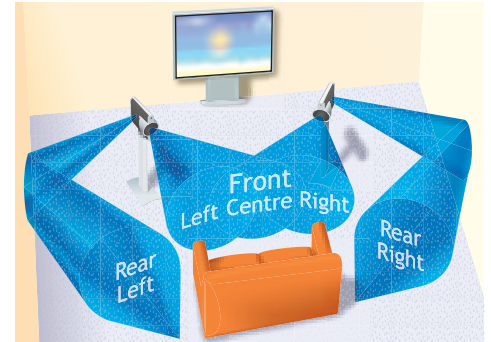
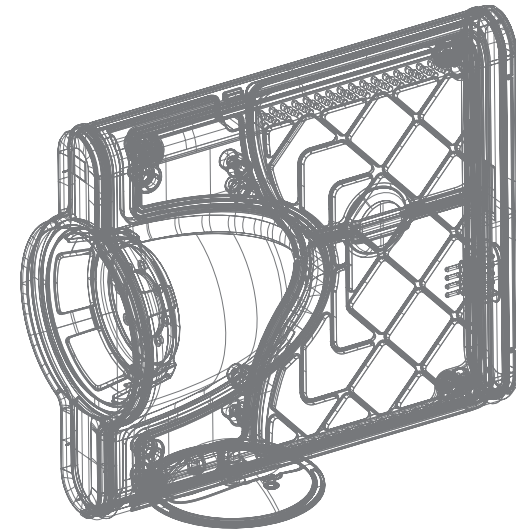

KIT works

By combining KEF's proven Uni-Q® 'point source' driver array from the award-winning KHT separates system with a unique new application of NXT® flat panel technology, KEF engineers discovered a way to deliver all the subtleties and spatial depth encoded in today's digital formats from just two small speakers and a bass unit.

Like all great ideas, the concept is simple. The vertical NXT flat panels behind the main arrays create virtual rear effects speakers, while the Uni-Q drivers create a perfect 'phantom' centre speaker right in the middle of the screen – just like the movies. The effect is certainly impressive, with pin-sharp dialogue and vocals appearing to come from the

performers' mouths as if they were physically there. The same is true for rear effects – with your eyes closed, you'd swear the sound was coming from behind you. The acoustic illusion of all three virtual speakers is accentuated by the Uni-Q driver configuration, which spreads the sound image over a much larger area than a conventional speaker. And as well as delivering hefty bass punch throughout the room from a 250mm (10") bass driver, the unobtrusive subwoofer contains the system's sophisticated high power 5 channel amplifier, allowing the DVD player to be exceptionally compact.

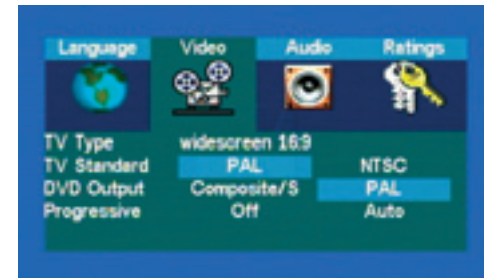

KEF Uni-Q Originally developed for KEF's legendary audiophile loudspeakers, the Uni-Q driver uses aerospace materials to engineer a high performance tweeter that's small enough to mount in the centre of the bass/midrange cone so that both act as a single point source. As this configuration disperses the sound over a much wider area, it has huge benefits for home theatre: speaker positioning is far more flexible, and everyone in the room enjoys the same clear, realistic 3D soundscape. It also creates a perfect 'centre speaker' image from the left and right channels in a way that conventional speakers simply can't.

Cast aluminium enclosures The beauty of die cast aluminium as a speaker enclosure is that it's acoustically inert. So you don't get cabinet vibrations interfering with the purity of the sound; and because there's no conventional box behind the drive units, there are no distorting internal resonances either. And with the matching DVD player/tuner, it gives the system a visual identity that hints at the radical technologies inside. It doesn't look like an ordinary home theatre system - because it isn't.

NXT flat panel technology The rear effects signal is directed to NXT panels mounted vertically behind the main drivers. KEF's innovation is to use freestanding (rather than wall-mounted) NXT panels, allowing the sound to reflect off the side walls to the back of the room. Like the dipole rear speakers of high-end home theatre systems, this generates the wide, diffuse soundfield you need for convincing ambient effects.

CD/DVD player/tuner The head unit is about the same size as the front speakers, and styled to match. Whatever you want to play - DVDs, SVCDs, CDs or MP3s, it automatically recognises what you've loaded. The decoding circuits also give you the full benefit of Dolby Digital, Dolby Pro Logic® II and DTS surround sound from any other equipment you play through the system. With clear displays and intuitive controls, the unit also houses an AM/FM radio with RDS (Europe only), alarm and sleep functions.

Bass effects With built-in amplifiers for all channels alongside the 250mm (10") bass driver, the omni-directional subwoofer can be placed wherever it suits you – even behind the TV or next to a wall. In any case, the mirror front panel and slim profile make its presence hardly noticeable. Until it starts playing, that is – because you certainly can't ignore the weight, depth and texture it adds to the complex sound image that surrounds you. Packing real punch for dramatic effects, it underscores on-screen action with an intensity that belies its compact size.

Ease of setup KEF instant theatre is exceptionally simple to use. It recognises whatever type of disc you load, and automatically configures the system accordingly; all you have to do is press 'play'. And although the presets are suitable for most rooms, you can easily customise the settings to suit your own personal preferences using the clear graphical menus on the setup screen.

switch on, sit back
relax and enjoy



KIT accessories

As you would expect of a complete system, KEF instant theatre comes with its own full-function remote control. The only additional items you may need are stands. Slim, stable and designed to enhance the distinctive lines of the other elements, matching stands are available in extruded aluminium. As well as positioning the drive units at exactly the right height when you're sitting, they incorporate an internal cable management system to preserve the clean, uncluttered look that defines the KIT concept.



KIT specifications

KIT100 speakers

Design	Two-way closed box satellite speaker
Drive units	100 mm (4 in.) Uni-Q array with 14 mm (0.6 in.) tweeter NXT flat panel array Magnetically shielded
Cabinets	Die cast aluminium
Finish	Stardust silver
Dimensions (H x W X D)	237 x 119 x 260 mm (9.33 x 4.7 x 10.23 in.)

KIT100 PSW subwoofer

Design	Closed box powered subwoofer
Drive unit	250 mm (10 in.) long throw unit
Amplifiers	5 x high power amplifier channels for subwoofer and main speakers
Finish	Stardust silver
Dimensions (H x W X D)	398 x 176 x 515 mm (15.6 x 6.9 x 20.3 in.)



KIT100 DVD

Formats supported	DVD, DVD-RW, DVD+RW, CD, CDR/RW, MP3 encoded CD
Tuner section	AM/FM with RDS facility (Europe only)
Audio inputs	Cable/satellite, VCR, TV (analogue & optical digital)
Audio output	Optical digital
Video inputs	Cable/satellite, VCR (S-video & composite)
Video outputs	Scart (Europe only), Component, with progressive scan, S-video, Composite
Aerial inputs	FM & AM (provided)
Cabinet material	Die cast zinc
Finish	Stardust silver
Display	Mirror finish, blue VFD display with auto-dim function
Control	Infra-red remote control
Dimensions (H x W X D)	59 x 324 x 262 mm (2.32 x 12.75 x 10.31 in.)

KEF instOnT dvd theatre



PLI463EN

KEF AUDIO (UK), Eccleston Road, Tovil, Maidstone, Kent, ME15 6QP U.K. Telephone: + 44 (0)1622 672261 Fax: + 44 (0)1622 750653 www.kef.com
KEF AMERICA, 10 Timber Lane, Marlboro, New Jersey 07746 U.S.A. Telephone: +(1) 732 683 2356 Fax: +(1) 732 683 2358 www.kefamerica.com
KEF and Uni-Q are registered trademarks. Uni-Q is protected under GB patent 2 236929 and U.S. Pat. No. 5,548,657. Worldwide patents pending. KEF reserve the right, in line with continuing research and development, to amend or change specifications. Dolby, Pro Logic, and the double-D symbol are registered trademarks of Dolby Laboratories. DTS is a registered trademark of Digital Theatre Systems Inc. *NXT is a trademark of New Transducers Limited.